

ARO

2" Band Clamp Models - BD Series

SPECIALTY PUMP

ARO's Band Clamp models features the Quick Knock Down (QKD) compression clamp system to facilitate easier cleaning, service and maintenance. 2" BD Series pumps are often used for transfer, filling and recirculation and batching in Chemical (ink), Marine and General Industrial markets.

Ratio:	1:1
Maximum GPM (LPM):	185 (700)
Displacement per cycle Gallons (Liters):	1.4 (5.3)
Air Inlet (Female):	3/4 - 14 NPTF-1
Fluid Inlet/Outlet:	2-11-1/2 NPTF -1 Rp 2(2-11 BSP parallel)
Max. operating pressure psi (bar):	120 (8.3)
Suspended solids max. dia. in. (mm):	1/4" (6.4)
Weight lbs (kg):	75 (34.02)
Maximum dry suction lift ft (m):	18 (5.4)
Maximum wet suction lift ft(m)	31 (9.4)
Sound Level: 70 PSI 60 Cycles/Min	85.0 db(A)
Muffler Included:	67389



Ordering

Position	1	2	3	4	5	6	7	8	9	10	11
Example:	BD20	X	X	A	S	X	X	X	A	X	X

Position 1 Model Series	Position 2 Center Section	Position 3 Connections	Position 4 Wetted Parts	Position 5 Hardware	Position 6 Seat Material	Position 7 Ball Material	Position 8 Diaphragm Material	Position 9
BD20 - Standard Pump	A - Aluminum	A - NPTF Thread B - BSP Thread	A - Aluminum	S - Stainless Steel	A - Santoprene® C - Hytrel® F - Aluminum S - 316L Stainless Steel	A - Santoprene® C - Hytrel® S - Stainless Steel T - PTFE	A - Santoprene® C - Hytrel® K - PTFE Composite T - PTFE/Santoprene®	Revision Level Position 10 & 11 Specialty Code Fluid control options for pump with electronic interface (BE20 model). See complete description on next page

* Acceptable for use in hazardous locations. - NEC / CEC: Class I&II, Div 1&2, Group A-
- ATEX: Zone 1&2, 21&22

Santoprene® is a registered trademark of ExxonMobil; Hytrel is a registered trademark of the DuPont Company

Accessories

Air Line Connection Kit | 66109 (Piggyback Filter/Regulator with gauge, pipe nipple and 5-foot air hose)

Service Repair Kits | 637421 (air motor for BD20A), 637494-XX,
637374-X (major air valve assembly)

Dimensions and performance curves on the reverse side.



R. A. ROSS & ASSOCIATES, INC.
Keeping process flowing since 1985

2231-A Ampere Drive, Louisville, KY 40299
502 267-8677 • 1 800-489-8677
Fax 502 266-7928 • www.raross.com



PUMPS • FILTERS • BLOWERS • MIXERS • REPAIRS • SPECIALTY • CUSTOM FABRICATIONS

**Ordering Position 10
Specialty Code 1
(Blank if no Specialty Code)**

- A - Solenoid 120VAC
 - B - Solenoid 12VDC
 - C - Solenoid 240VAC
 - D - Solenoid 24VDC
 - E - 12vDC NEC/CEC*
 - F - 24vDC NEC/CEC*
 - G - Solenoid 12VDC ATEX/IECex*
 - H - Solenoid 24VDC ATEX/IECex*
 - J - 120VAC NEC/CEC*
- K - Solenoid 220VAC ATEX/IECex*
 - N - Solenoid with no coil 0 - Standard Valve Block (No Solenoid) P - Ported Motor (No major valve provided)

**Ordering Position 11
Specialty Code 2
(Blank if no Specialty Code)**

- F - End of stroke feedback
- G - End of Stroke ATEX/IECex*
- O - No Option

* Acceptable for use in hazardous locations.
 - NEC / CEC: Class I&II, Div 1&2 , Group A-D
 - ATEX: Zone 1&2, 21&22

2" BD Series Dimensions and Flow Charts

Dimensions shown are for reference only,
they are displayed in inches and millimeters (mm)

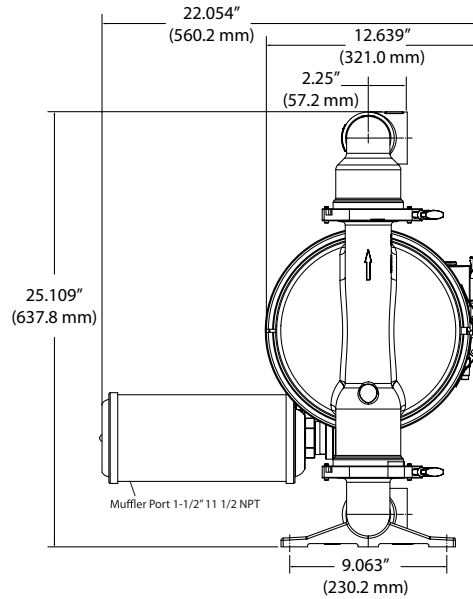
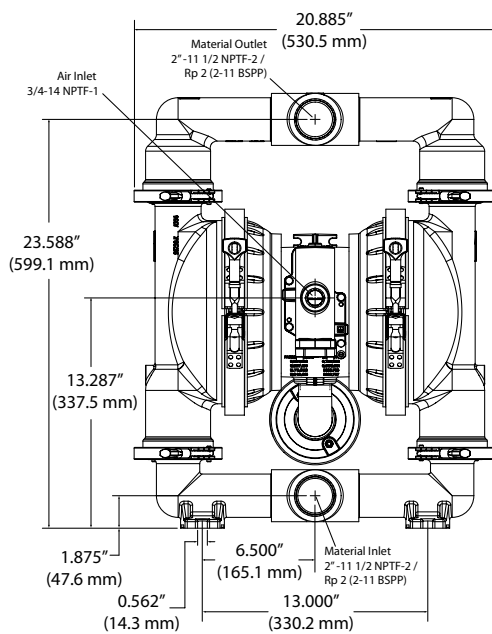

Performance Curves
BD20X-XXX-AXX Pump 2" Band Clamp Diaphragm Pump

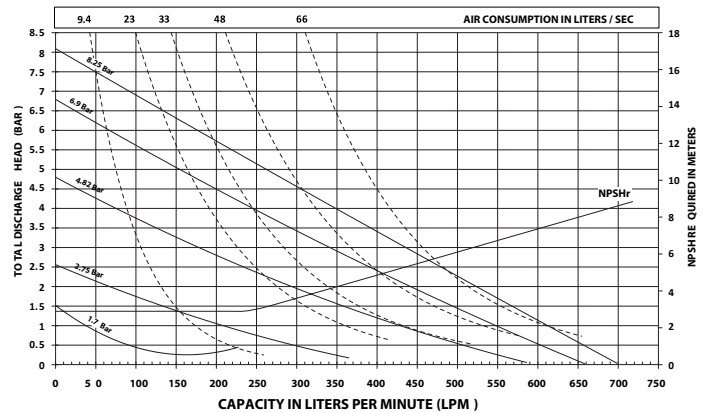
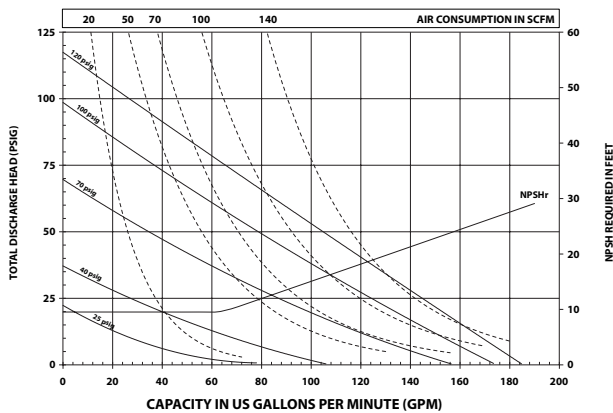

Performance based on an elastomeric fitted pump (BD20A-AAS-AAA-A), flooded suction with water at ambient conditions. Due to varying materials of construction, assembly configurations and operating conditions, published data is for reference only